

# Model AR-6500 series

## Contact & Non-Contact Thermometer

AR-6500 series infrared thermometers are capable of non-contact temperature measurement and come with contact type thermometer functions.

### AR-6500模式系列

AR-6500模式系列为非接触式红外线温度计，同时也搭配了接触式温度计功能。

AR-6500シリーズは、非接触で温度測定が可能な放射温度計に、接触式温度計の機能を搭載した温度計です。



**AR-6500 Series**  
Handy type

### Features

- Broad measurement range
- Small measurement area
- Wide range of emissivity settings
- Automatic emissivity setting using contact-type probe

### Specifications

Model	AR-6500	AR-6501	AR-6500-H	AR-6501-H
Measurement range	-50~500°C		0~1200°C	
Resolution	0.1°C		1°C	
Laser aiming	●	●	●	●
Contact mode	●	●	●	●
Measurement accuracy	*TABLE I		*TABLE II	
Reference junction compensation accuracy	±0.2°C at 25±10°C			
Temperature coefficient	±0.01% of full scale °C			
Power supply	Ni-Cd rechargeable battery (4AA)			
Battery life	30 hours~ (10 hours when laser is used continuously)			
Environmental limit	Operation	0~40°C, 0~80%RH (Without dew)		
	Storage	-20~50°C, 0~85%RH (Without dew)		
Analog output (*Table III)	—	1mV/°C	—	1mV/°C
Weight	approx. 400g			
Accessories	Manual, Soft case, Lens cap, Charger			
	—	Output cable	—	Output cable

**\*TABLE I**

AR-6500, AR-6501		Field of view				
		φ15	φ19	φ52	φ95	φ137
		50	500	1000	1500	2000
		unit : mm				
Non-contact	250~500°C	± (0.8% of reading + 1digit)				
	0~250°C	± (2°C + 1digit)				
	-50~ 0°C	± (3°C + 1digit)				
Contact	-50~500°C	± (0.05% of reading + 0.1°C) ± 1digit				

### Non-contact mode

Detector	Thermopile
Spectral response	8~14 μm
Repeatability	± (0.4% of reading + 1digit)
Response time	approx. 300ms
A-constant adjustment	0.10~2.00 (0.01 step)
Laser aiming	L2 models meet ICE Class2

### Contact mode

Input	Thermocouple Type:K
Sampling time	approx. 300ms
Input connector	ANP connector (Miniature plug)

**\*TABLE II**

AR-6500-H, AR-6501-H		Field of view			
		φ12	φ33	φ60	φ87
		500	1000	1500	2000
		unit : mm			
Non-contact	600~1200°C	± (0.5% of reading + 1 digit)			
	250~ 600°C	± (3°C + 1digit)			
	0~ 250°C	± (4°C + 1digit)			
Contact	0~1200°C	± (0.1% of reading + 1 digit)			

### Dimensions

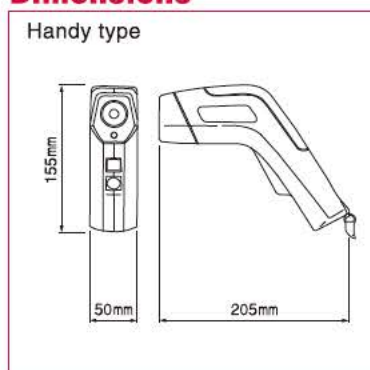

### Accessories

**Charger**  
B-115/230-5.5  
(for AC115V or 230V)



Not CE-approval

**\*TABLE III**

Output rate	1mV / °C
Accuracy	± (0.15% of F/S+1mV) : at 25±5°C
	± (0.15% of F/S+1mV) ±0.01% of F/S : except 25°C±5°C