

Height Gage

A standard measuring tool of industry

Vernier Height Gage

SERIES 514, 506 — Standard Height Gage with Adjustable Main Scale

- Fits comfortably in the hand and moves easily on the surface plate.
- The main scale slides and clamps within the column for quick and convenient zero-setting.
- Large locking knobs are used both for the slider and fine adjustment clamps to make clamping easy and secure.
- Operability of slider has been improved.
- Large main-scale engraving for fatigue-free

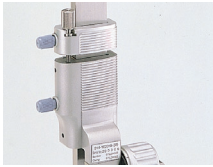
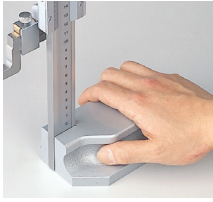

working.

- Carbide-tipped scriber (No. **07GZA000** for Nos. **514-102/104/106/103/105/107**, No. **905200** for Nos. **514-108** and **109**, and No. **900390** for No. **514-170**) is provided as a standard accessory. (Scriber clamp No. **05GZA033** for Code No. **514-102/104/106/108/103/105/107/109**, and No. **905008** for No. **514-170**)
- For precision Black Granite Surface Plates, refer to page E-51.

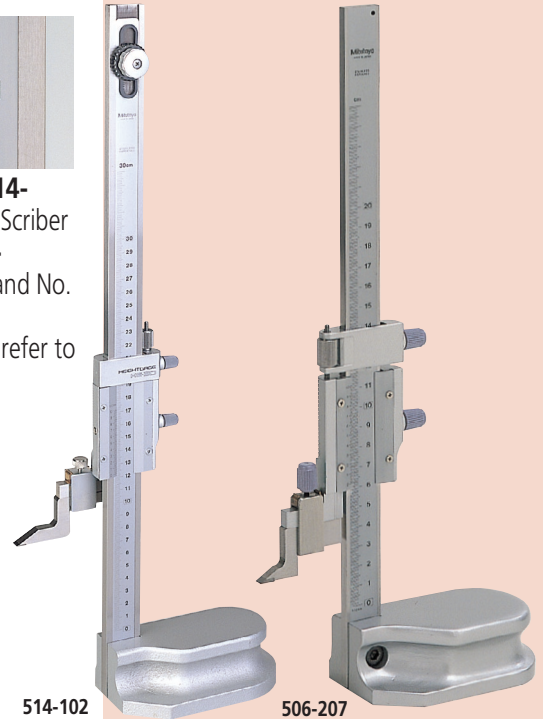
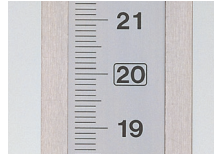

SPECIFICATIONS

Metric

Order No.	Range	Graduation	Accuracy	Scale adjustment	Fine feed	Height	Mass	Remarks
506-207	0 - 200mm	0.02mm	±0.03mm	—	4mm	341mm	1.4Kg	—
514-102	0 - 300mm		±0.04mm	15mm		525mm	3.1Kg	—
514-104	0 - 450mm		±0.05mm		675mm	3.4Kg	—	
514-106	0 - 600mm		±0.07mm	25mm	7mm	870mm	7.4Kg	—
514-108	0 - 1000mm	±0.07mm	6mm		1340mm	20Kg	—	
514-170	0 - 1500mm	0.05mm	±0.18mm	—	20mm	1760mm	26Kg	with magnifier

Inch/Metric

Order No.	Range	Graduation	Accuracy	Scale adjustment	Fine feed	Height	Mass	Remarks
506-208	0 - 8"	.001"/0.02mm	±.001"	—	.16"	341mm	1.4Kg	—
514-103	0 - 12"		±.002"	.6"		525mm	3.1Kg	—
514-105	0 - 18"		±.002"		675mm	3.4Kg	—	
514-107	0 - 24"		±.003"	1"	.27"	870mm	7.4Kg	—
514-109	0 - 40"	±.003"	.24"		1340mm	20.0 Kg	—	

DIMENSIONS

