

Calipers

An industry standard in measuring tools

SuperCaliper

SERIES 500 — No battery or origin reset needed for IP67 digital caliper

- Top-of-the-line digital caliper. Solar type caliper with no battery and IP67 protection assures waterproof reliability.

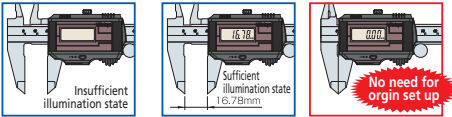

- With no annoying origin restoration necessary, a measurement can be started any time and there is no restriction on operating speed.
- The impact resistance of the display unit has been increased for improved usability in workshop conditions.

- Waterproof function makes this SuperCaliper suitable for use in an environment containing large amounts of cutting fluid or coolant. Operability is equivalent to the mechanical type caliper.

- This SuperCaliper uses components that do not contain harmful substances and is compatible with RoHS Directives.
- Slider operation is smooth and comfortable.

High quality guide surface finish for smooth slider movement

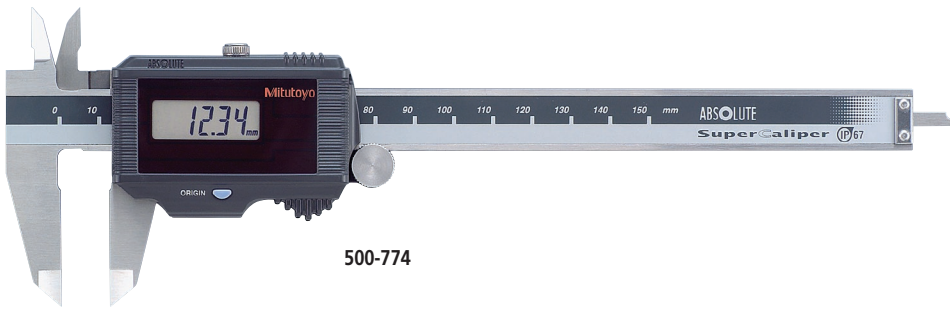

500-774

SPECIFICATIONS

Metric				Inch/metric			
Order No.	Range	Remarks	Mass	Order No.	Range	Remarks	Mass
500-776	0 - 150mm	with data output	180g	500-786	0 - 6"	with data output	180g
500-777	0 - 200mm		210g	500-787	0 - 8"		210g
500-774	0 - 150mm	w/o data output	180g	500-784	0 - 6"	w/o data output	180g
500-775	0 - 200mm		210g	500-785	0 - 8"		210g

DIMENSIONS

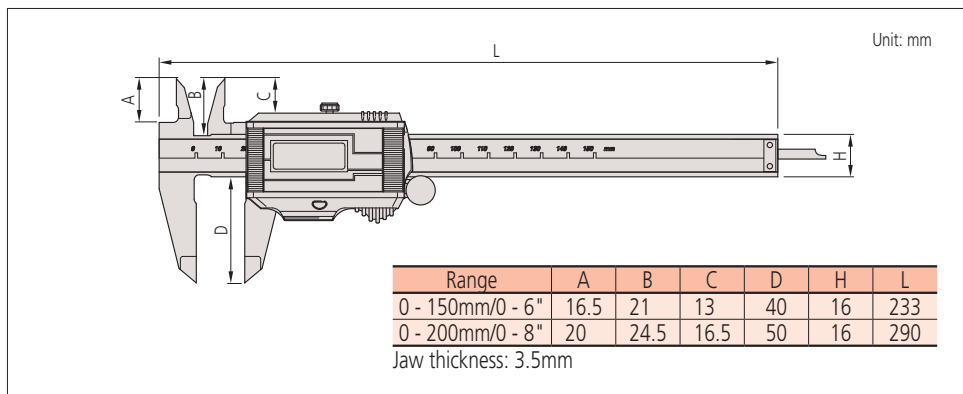

ABSOLUTE™ (Refer to page IX for details.)

IP67 (Refer to page IX for details.)



(Refer to page IX for details.)



An inspection certificate is supplied as standard. Refer to page IX for details.

IP67 protection level

Level 6: Dust-proof.
No ingress of dust allowed.

Level 7: Protected against water penetration.
Ingress of water in quantities causing harmful effects shall not be possible when the enclosure is temporarily immersed to a depth of 1 meter in water under standardized conditions of pressure and time (30 min.).

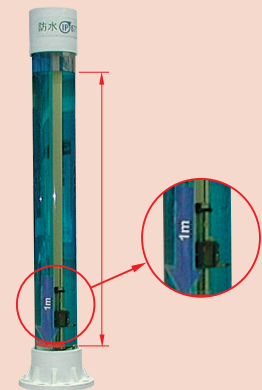

Demonstration device

Technical Data

Resolution: 0.01mm or .0005"/0.01mm
Accuracy: ±0.02mm (excluding quantizing error)
Repeatability: 0.01mm
Quantizing error: ±1 count
Dust/Water protection level: IP67*
Power supply: Solar cell**
Display: LCD
Scale type: ABSOLUTE electromagnetic induction linear encoder
Max. response speed: Unlimited
* This model is not waterproof type. Therefore, rustproofing shall be applied after use.
** Can be used continuously above 60lux ambient illumination.



Functions

Origin-set: Absolute origin position can be changed.
 Alarm: Error message is displayed and measurement functions become inoperative if:

- Tool is turned on when both illumination and charging voltage are insufficient.
- Main unit is extremely polluted and miscalculation occurs in the display unit.



Air leak test equipment for water resistance inspection

Generally, an air leak test is adopted for evaluating water resistance.

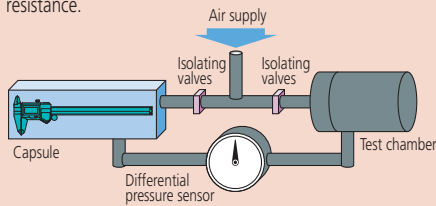

Procedure: Place the measuring tool inside the capsule and seal it. Then fill the capsule and the test chamber with air at the required pressure and close the isolating valves. If there is no leak in the measuring tool, the differential pressure sensor will read zero, because the amount of air inside the test chamber is unchanging. However, if there is a leak in the measuring tool, the differential pressure sensor will show a non-zero reading due to a decrease in pressure inside the test chamber as air leaks into the tool. By detecting this differential pressure, GO/NG judgment for the severity of the leak is performed. This air leak test is performed for all ABS coolant proof calipers and coolant proof micrometers.



Air leak test equipment for ABS coolant proof caliper

Optional accessories

(Dedicated for the models equipped with a digimatic output function (Code No. 500-776, 500-777, 500-786 and 500-787))
 For details, refer to page A-21.

- **Connecting cables for IT/DP/MUX***
 - 05CZA624: SPC cable with data button (1m)
 - 05CZA625: SPC cable with data button (2m)
- **USB Input Tool Direct**
 - 06ADV380A: SPC cable for USB-ITN-A (2m)
- **Connecting cables for U-WAVE-T**
 - 02AZD790A: SPC cable for U-WAVE with data button (160mm)
 - 02AZE140A: SPC cable for foot switch



* Cannot be used for other than water resistant type Digital calipers with external output function.



About the charge function (SuperCaliper)

The minimum illumination required in the uncharged state is 60lux.

As shown in the table 'JIS Z 9110 Artificial Illumination Intensity Standard', this SuperCaliper can be used with confidence in a normal work environment.

The charge function allows the operator to use the SuperCaliper without interrupting work even if the ambient illumination is temporarily insufficient.

- In the fully charged state this SuperCaliper can operate for approximately one hour in an environment of 50lux illumination (less than the minimum necessary illumination intensity).
- The time necessary for full charge varies according to the charging conditions. If the SuperCaliper is left unused in an illumination of 500 lux (usual for manufacturing environments), it takes approximately one hour to reach full charge.

Illumination (lx)	Site (possible operations)
1500	
1000	Design room, drafting room (Fine visual work)
750	
500	Conference room, control room (Usual manufacturing environment) (Normal visual work)
300	
200	Machine room, electric room, lecture hall (Rough visual work)
150	
100	Corridor, passage, stairs (Very rough visual work)
75	
50	Emergency staircase, warehouse (Loading, unloading work)
30	
20	

Excerpts from JIS Z 9110 Artificial illumination Intensity Standard