



# LONG STROKE DIAL GAUGES



DI-10078



DI-8058



DI-5058



DI-3058

## DIMENSIONS

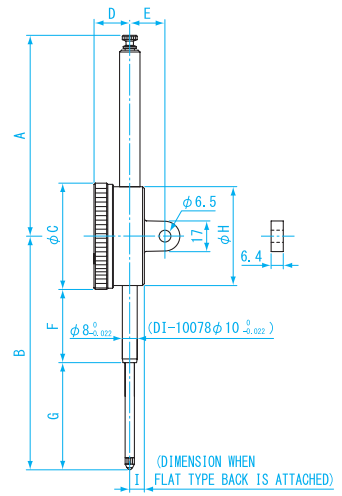

Units : mm

Model No.	A	B	C	D	E	F	G	H	I
DI-3058	37.5	86.5	58	19	19.5	19.5	38	53.5	8.5
DI-5058	108.5	126	58	19	19.5	39.5	57.5	53.5	8.5
DI-8058	138.5	168.5	58	19	19.5	51.5	88	53.5	8.5
DI-10078	167.5	208	78	20	20.5	61	108	69	10

- USE**
  - Long stroke measurement
- MATERIALS**
  - Body : steel
- FEATURES**
  - O-Ring sealed between inner and outer lid to protect from water or oil
  - Jeweled bearings
  - White scale plate
  - Flat type back and center-lug back included

Order No.	Model No.	Graduation (mm)	Measuring Range (mm)	Dial Reading (mm)	Backlash Error (μm)	Measuring force less than (N)	1 Revolution (mm)	Indication Error 1/10 rev (μm)	Error over entire range (μm)	Repeatability (μm)	Weight
151505	DI-3058	0.01	0~ 30	0-100	7	3.0	1	14	±35	5	210g
151506	DI-5058	0.01	0~ 50	0-100	9	3.5	1	15	±40	5	270g
151507	DI-8058	0.01	0~ 80	0-100	11	4.0	1	—	±50	6	290g
151508	DI-10078	0.01	0~100	0-100	15	4.5	1	—	±50	6	530g

※ For vertical measurements please keep measurement head above shaft

DIAL GAUGES

DIAL GAUGES

DIAL INDICATORS

THICKNESS GAUGES

BORE GAUGES

CALIPER GAUGES

HARDNESS-TENSION GAUGE

MAGNETIC BASE