

***SD Card real time data recorder
pH/ORP, DO, CD, TDS, Salt all in one***

WATER QUALITY METER

Model : WAC-2019SD



Your purchase of this ENVIRONMENT METER marks a step forward for you into the field of precision measurement. Although this Meter is a complex and delicate instrument, its durable structure developed. Please read the following instructions carefully and always keep this manual within easy reach.

OPERATION MANUAL

TABLE OF CONTENTS

1. FEATURES.....	1
2. SPECIFICATIONS.....	3
2-1 General Specifications.....	3
2-2 Electrical Specifications.....	5
3. FRONT PANEL DESCRIPTION.....	10
4. MODE SELECTION.....	12
5. PH/mV MEASURING and CALIBRATION PROCEDURE.....	13
6. CONDUCTIVITY/TDS MEASURING and CALIBRATION PROCEDURE.....	19
7. SALT MEASURING and calibration PROCEDURE.....	23
8. DO (Dissolved Oxygen) MEASURING and CALIBRATION PROCEDURE.....	25
9. OTHER FUNCTION.....	31
9-1 Data Hold.....	31
9-2 Record (Max./ Min. reading).....	31
9-3 LCD brightness select.....	32
10. DATALOGGER.....	32
10-1 Preparation before execute datalogger function.....	32
10-2 Auto Datalogger (Set sampling time \geq 1 second).....	33
10-3 Manual Datalogger (Set sampling time = 0 second).....	34
10-4 Check time and sampling time information.....	35
10-5SD Card Data structure.....	35
11. Saving data from the SD card to the computer.....	37
12. ADVANCED SETTING.....	39
13. POWER SUPPLY from DC ADAPTER.....	47
14. BATTERY REPLACEMENT.....	47
15. SYSTEM RESET.....	47
16. RS232 PC SERIAL INTERFACE.....	48
17. OPTIONAL ACCESSORIES.....	49
18. PATENT.....	51

1. FEATURES

- * One meter for multi purpose operation :
PH/ORP, CD/TDS, Dissolved Oxygen, Salt measurement.
- * pH : 0 to 14.00 pH, ORP : ± 1999 mV.
- * Conductivity : 20.00 uS/200.0 uS/2.000 mS/20.00 mS/200.0 mS.
- * Dissolved oxygen : 0 to 20.0 mg/L.
- * Salt : 0 to 12 % salt (% weight).
- * Optional PH, ORP, CD/TDS/Salt, Dissolved Oxygen and ATC probe.
- * DC 1.5V (UM-3, AA) x 6 PCs or DC 9V adapter in.
- * PH meter function can select PH or ORP.
- * PH measurement can select ATC or manual temperature adjustment.
- * PH measurement can make the auto calibration for pH 7, pH 4 and pH 10 or other value.
- * Conductivity measurement can select uS/mS or TDS
- * Conductivity measurement can select Temp. Coefficient of measurement solution.
- * ATC for the conductivity measurement.
- * Dissolved oxygen meter use the polar graphic type oxygen probe with temperature sensor, high precision measurement for Dissolved Oxygen (DO) and temperature measurement.
- * Heavy duty dissolved oxygen probe, probe head can connect with BOD bottle.
- * DO use the automatic Temp. compensation.
- * DO meter build in " % SALT " & " Mountain Height " compensation value adjustment.
- * Separate probe, easy for operation of different measurement environment.

- * Wide applications: water conditioning, aquariums, beverage, fish hatcheries, food processing, photography, laboratory, paper industry, plating industry, quality control, school & college.
- * Real time SD memory card Datalogger, it Built-in Clock and Calendar, real time data recorder , sampling time set from 1,2,5,10,30,60,120,300,600,1800,3600 sec
- * Manual datalogger is available (set the sampling time to 0), during execute the manual datalogger function, it can set the different position (location) No. (position 1 to position 99).
- * Innovation and easy operation, computer is not need to setup extra software, after execute datalogger, just take away the SD card from the meter and plug in the SD card into the computer, it can down load the all the measured value with the time information (year/month/date/ hour/minute/second) to the Excel directly, then user can make the further data or graphic analysis by themselves.
- * SD card capacity : 1 GB to 16 GB.
- * TFT LCD easy reading.
- * Can default auto power off or manual power off.
- * Data hold, record max. and min. reading.
- * Microcomputer circuit, high accuracy.
- * Power by UM3/AA (1.5 V) x 6 batteries or DC 9V adapter.
- * RS232/USB PC COMPUTER interface.

2. SPECIFICATIONS

2-1 General Specifications

Circuit	Custom one-chip of microprocessor LSI circuit.	
Display	TFT LCD size : 2.4"	
Measurement Function	PH/ORP Conductivity/TDS/Salt/Hardness/Resister Dissolved Oxygen	
Datalogger Sampling Time Setting range	Auto	1,2,5,10,30,60,120,300,600,1800,3600 sec. @ <i>Sampling time can set to 1 second, but memory data may loss.</i>
	Manual	Push the data logger button once will save data one time. @ <i>Set the sampling time to 0 second.</i> @ <i>Manual mode, can also select the 1 to 99 position (Location) no.</i>
Memory Card	SD memory card. 1 GB to 16 GB.	
Advanced setting	<ul style="list-style-type: none"> * SD FORMAT * Set clock time (Year/Month/Date,Hour/Minute/Second) * Set sampling time * Auto power OFF management * Set beep Sound ON/OFF * Decimal point of SD card setting * Set temperature unit to °C or °F * Set DO salt% compensation value * Set DO height (meter) compensation value * Set DO height (feet) compensation value * Set CD temperature compensation factor * Set pH manual Temp. compensation value 	
Data Hold	Freeze the display reading.	
Memory Recall	Maximum & Minimum value.	

Sampling Time of Display	Approx. 1 second.
Data Output	RS 232/USB PC computer interface. * <i>Connect the optional RS232 cable UPCB-02 will get the RS232 plug.</i> * <i>Connect the optional USB cable USB-01 will get the USB plug.</i>
Operating Temperature	0 to 50 °C.
Operating Humidity	Less than 85% R.H.
Power Supply	* Alkaline or heavy duty DC 1.5 V battery (UM3, AA) x 6 PCs, or equivalent.
	* DC 9V adapter input. (AC/DC power adapter is optional).
Power Current	Normal operation (w/o SD card save data : <i>Approx. DC 22 mA.</i>
	When SD card save the data : <i>Approx. DC 37 mA.</i>
	* <i>Depending on the brightness of LCD, the power consumption will increase approx. 22 ~ 37 mA.</i>
Weight	489 g/1.08 LB.
Dimension	177 x 68 x 45 mm (7.0 x 2.7x 1.9 inch)
Accessories Included	* Instruction manual..... 1 PC * Hard carrying case (CA-06)..... 1 PC * Conductivity/TDS probe, Salt probe, CDPB-04..... 1 PC

Optional Accessories	* PH electrode.....	PE-03, PE-11, PE-01, PE06HDA, PE-04HD, PE-03K7
	* ATC probe (Automatic Temperature Probe).....	TP-07
	* pH 7 buffer solution.....	PH-07
	* pH 4 buffer solution.....	PH-04
	* Conductivity/TDS probe, Salt probe.....	CDPB-03
	* 1.413 mS Conductivity Standard Solution.....	CD-14
	* Oxygen probe.....	OXPB-11
	* Spare Probe head with Diaphragm set	OXHD-04
	* Probe-filling Electrolyte.....	OXEL-03
	* ORP Electrode.....	ORP-14
SD memory card (4 GB) AC to DC 9V adapter. USB cable, USB-01. RS232 cable, UPCB-02. Data Acquisition software, SW-U801-WIN.		

2-2 Electrical Specifications (23±5 °C)

A. PH/mV

PH Electrode	Optional, Any PH electrode with BNC connector.	
Measurement	PH	0 to 14 PH
	mV	-1999 mV to 1999 mV
Input Impedance	10 ¹² ohm	
Temperature Compensation for pH measurement	Manual	0 to 100 °C, be adjusted by push button on front panel.
	Automatic (ATC)	With the optional temperature probe (TP-07) 0 to 65 °C.

pH Calibration	PH7, PH4, and PH10, 3 points calibration ensure the best linearity and accuracy.
Optional probe and accessories	<ul style="list-style-type: none"> * PH electrode..... PE-03, PE-11, PE-01, PE06HDA PE-04HD, PE-03K7 * ATC (automatic temperature probe)..... TP-07 * pH 7 buffer solution..... PH-07 * pH 4 buffer solution..... PH-04 * ORP electrode..... ORP-14

Measurement	Range	Resolution	Accuracy
PH	0 to 14 PH	0.01 PH	±(0.02 PH + 2 d)
mV	0 to ±1999 mV	1 mV	±(0.5% + 2 d)

* PH accuracy is based on calibrated meter only.

B. Conductivity

Conductivity probe	Optional, Carbon rod electrode for long life.
Function	<ul style="list-style-type: none"> * Conductivity (uS, mS) * TDS (Total Dissolved Solids, PPM) * Temperature (°C, °F)
Temperature Compensation	Automatic from 0 to 60 °C (32 - 140 °F), with temperature compensation factor variable between 0 to 5.0% per C.
Probe Operating Temp.	0 to 60 °C.
Probe Dimension	Round, 22 mm Dia. x 120 mm length.
Optional probe and accessories	<ul style="list-style-type: none"> * Conductivity probe..... CDPB-03 * 1.413 mS Conductivity Standard Solution..... CD-14

4. Hardness

Range	Measurement	Resolution	Accuracy
10 PPM	0 to 10.00 PPM	0.01 PPM	±(2% F.S.+1d) * F.S. - full scale
100 PPM	0 to 100 PPM	0.1 PPM	
1,000 PPM	100 to 1,000 PPM	1 PPM	
10,000 PPM	1,000 to 10,000 PPM	10 PPM	
100,000 PPM	10,000 to 100,000 PPM	100 PPM	

5. Resistivity

Range	Measurement	Resolution	Accuracy
automatic Range	5 ohm - cm to 99.99 M ohm - cm	1 ohm to 0.01 M ohm	±(2% F.S.+1d) * F.S. -full scale

6. Temperature

Function	Measuring Range	Resolution	Accuracy
°C	0 °C to 60 °C	0.1 °C	±0.8 °C
°F	32 °F to 140 °F	0.1 °F	±1.5 °F
* @ 23±5 °C			

C. Dissolved oxygen

Oxygen Probe	Optional, The polarographic type oxygen probe with	
Measurement & Range	Dissolved Oxygen	0 to 20.0 mg/L (liter).
	Oxygen in Air	0 to 100.0 %.
	Temperature	0 to 50 °C.
Resolution	Dissolved Oxygen	0.1 mg/L.
	Oxygen in Air	0.1 % O2 .
	Temperature	0.1 °C.
Accuracy (23±5 °C)	Dissolved Oxygen	±0.4 mg/L.
	Oxygen in Air	±0.7% O2.
	Temperature	±0.8 °C/1.5 °F.
Probe Compensation & Adj.	Temperature	0 to 50 °C, Automatic
	Salt	0 to 50 % Salt
	Height (M. T.)	0 to 8900 meter
Probe Weight	335 g/0.74 LB (batteries & probe included)	
Probe Size	190 mm x 28 mm Dia. (7.5" x 1.1" Dia.)	
Optional Accessories	* Oxygen probe.....	OXPB-11
	* Spare Probe head with Diaphragm set	OXHD-04
	* Probe-filling Electrolyte.....	OXEL-03

@ Above specification tests under the environment RF Field Strength less than 3 V/M & frequency less than 30 MHz only.

3. FRONT PANEL DESCRIPTION

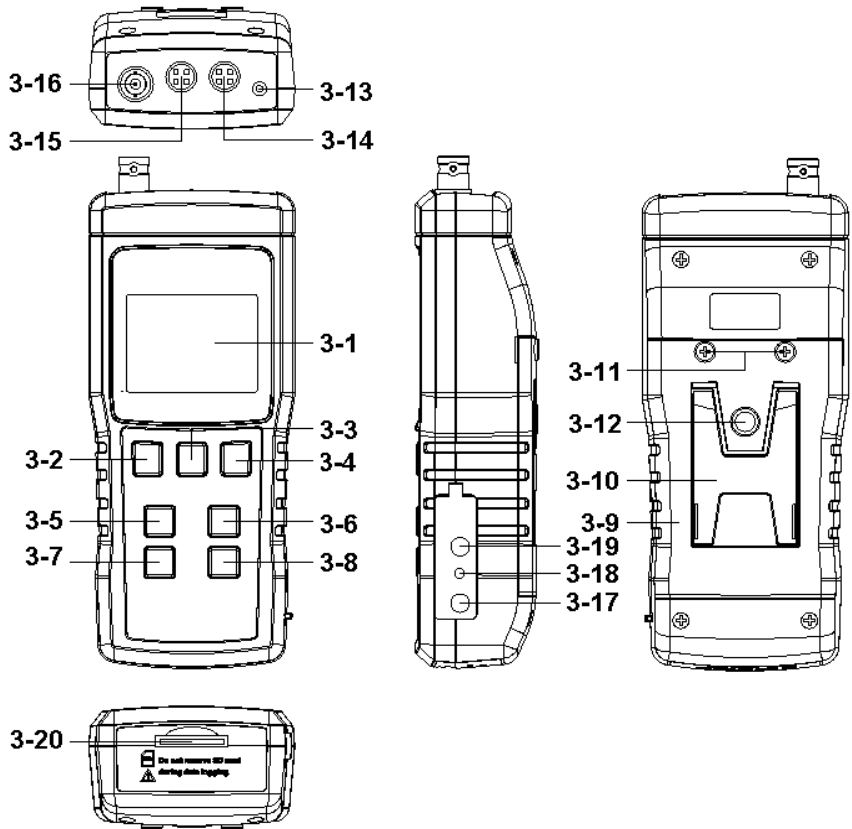

Fig. 1

- 3-1 Display
- 3-2 Power Button (Backlight Button)
- 3-3 Hold Button (ESC Button)
- 3-4 REC Button (Enter Button)
- 3-5 Range Button (▲ Button)
- 3-6 Function Button (▼ Button, Screen Button)
- 3-7 SET Button (Time Button)
- 3-8 Logger Button (ENTER Button)
- 3-9 Battery Compartment/Cover
- 3-10 Stand
- 3-11 Battery Cover Screw
- 3-12 Tripod Fix Nut
- 3-13 Temp. Socket (PH ATC Socket)
- 3-14 DO Socket
- 3-15 CD Socket
- 3-16 PH Socket (BNC Socket)
- 3-17 DC 9V Power Adapter Input Socket
- 3-18 Reset Button
- 3-19 RS-232 Output Terminal
- 3-20 SD card socket

4. MODE SELECTION

1) Turn on the meter by pressing the " Power Button "
 (3-2, Fig. 1) > 2 seconds.

* *Pressing the " Power Button " (3-2, Fig. 1)
 continuously and > 2 seconds again will turn off the meter.*

2) The meter at same time can measure three kind measure Mode
 and can select eight kind screen as listed below :
 Pressing and hold the " Function Button " (3-6, Fig. 1), the meter
 Display will show the following screen in sequence :

- a. pH, mV (ORP)
- b. Conductivity.
- c. Dissolved Oxygen
- d. pH/ Conductivity
- e. Conductivity/oxygen
- f. pH/ Oxygen
- g. pH/ Conductivity/Oxygen
- h. pH/Temp./ Conductivity/Oxygen



when the screen show the desired Function, just release the
 " Function Button "(3-6, Fig. 1), the meter will show this function
 measure screen with default.

***Although select single function measure screen, but other
 function measure , still being executed.**

5. PH/mV MEASURING and CALIBRATION PROCEDURE

The meter default function are following :

- * The display unit is set to pH.
- * The temperature unit is set to °C.
- * Manual ATC (without connect the ATC probe)
- * Auto power off.
- * The sampling time of data logger function is 2 seconds.

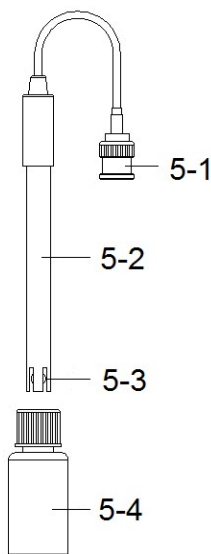

Fig. 2

If the meter is first time to connect the pH electrode, it should make the calibration before operation, the calibration procedures refer to chapter 5-4, page 15.

5-1 pH measurement (manual Temp. compensation)

- 1) Power on the meter by pressing " Power Button " (3-2, Fig. 1) once.
Press and hold the "Function Button" (3-6, Fig. 1) Select the Meter's measurement Mode to " PH ", refer to Chapter 4, page 12.
- 2) Prepare the pH Electrode (optional), install the " Probe Plug " (5-1, Fig. 2) into the " PH Socket/BNC Socket " (3-16, Fig. 1).
- 3) **Adjust the manual Temp. value same as the solution's temperature exactly, the procedures refer chapter 12-13, page 46.**
- 4) Hold the " Electrode Handle " (5-2, Fig. 2) by hand and let the " Sensing head " (5-3, Fig. 2) immersed wholly into the measured solution and little shake the electrode.
- 5) The main display will show the pH value, the bottom display will show the setting manual Temp. value.

5-2 PH measurement (ATC , automatic Temperature)

- 1) All the procedures are same as
5-1 PH measurement (manual Temp. compensation)
but should prepare one temperature probe (optional, TP-07), insert the TP-07's plug into the " Temp. Socket " (3-13, Fig. 1), immerse the sensing head of temperature probe (TP-07) into the measurement solution.
- 2) The main display will show the pH value, the bottom display will show the sensing Temp. value of the measured solution (measured from ATC probe, TP-07).

When not use the Electrode, it should immerse the " Electrode sensing head " (5-3, Fig. 2) into the " Protection bottle " (5-4, Fig. 2)

5-3 mV Measurement

The instrument build in mV (millivolt) measurement function, which enable you to make ion-selective, ORP (oxidation-reduction potential), and other precise mV measurements.

- 1) Under the meter is operated under the " PH " Mode.
Press the " Function Button " (3-6, Fig. 1) once, the measure unit " pH " will change to " mV "
** Press the : Function Button " once will return to " pH " function.*
- 2) Prepare the ORP Electrode (optional, ORP-14), install the " Probe Plug " of ORP electrode into the " PH Socket/BNC Socket " (3-16, Fig. 1).
- 3) The Display will show the mV value.

5-4 pH calibration

Calibration Consideration

The most ideal pH ELECTRODE generates 0 mV at pH 7.00 (177.4 mV at PH 4) and meter has been always calibrated with signals which simulate the most ideal pH ELECTRODE (based on 25 °C ambient environment). However not every pH ELECTRODE is as accurate as the most ideal one, so calibration procedures are necessary to be done before the first time measurement.

In addition to the first time measurement, users are also recommended to execute the calibration procedures to ensure the high accuracy measurement.

Required Equipment for Calibration

- 1) pH ELECTRODE (optional).
- 2) pH buffer solutions (optional).

Calibration Procedure

- 1) Prepare the pH Electrode (optional), install the " Probe Plug " (5-1, Fig. 2) into the " PH Socket/BNC Socket " (3-16, Fig. 1).
- 2) Power on the meter by pressing " Power Button " (3-2, Fig. 1) > 2 seconds, press the "Function (3-6 Fig1)" Select the Meter's measurement screen to the only " PH "screen.
- 3) Adjust the " Temperature Compensation Value " to make it same as the temperature value of the pH buffer solution.

- * **Manual temperature compensation value adjustment procedure, refer to 12-13, page 46.**
- * **Automatic temperature compensation, it should plug in the ATC probe (optional, TP-07).**

- 4) Hold the " Electrode Handle " (5-2, Fig. 2) by hand and let the " Sensing head " (5-3, Fig. 2) immersed wholly into the measured solution and little shake the probe. Display will show the PH value.

- * **If use the ATC probe, should immerse the ATC probe into the solution together.**

5) Use the two fingers to press the " ▲ Button " (3-5, Fig. 1), and " ▼ Button " (3-6, Fig. 1) ,Until Display will show the following screen then release the both fingers.

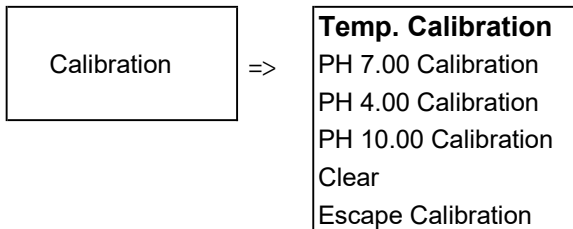

6) Press the " ▲ Button " (3-5, Fig. 1) or " ▼ Button " (3-6, Fig. 1) once to select want to calibration point, then press enter key ,waiting measur value stable , then use " ▲ Button " (3-5, Fig. 1) or " ▼ Button " (3-6, Fig. 1), adjustment calibration point value to as the standard solution value.

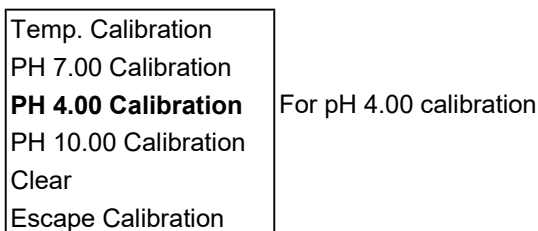
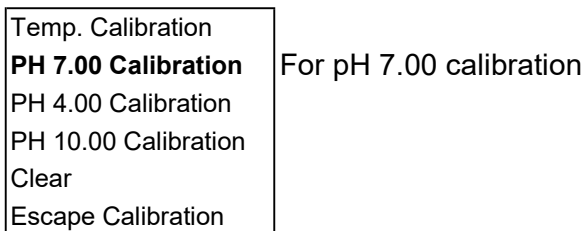

- * After the above pH 7, 4, 10 screen is selected, then cooperate the relative standard solution, for example the ***pH 7.00 calibration point should cooperate the pH 7.00 standard solution.*** ***pH 4.00 calibration point should cooperate the pH 4.00 standard solution.*** Press the " Enter Button " (3-8, Fig. 1) will save the calibration data and finish the calibration procedures.
- * If select the clear point, press the " Enter Button " (3-8, Fig. 1) will clear existing calibration data.
- * If select the Escape Calibration, press the " Enter Button " (3-8, Fig. 1) will Escape Calibration Function and back normal measurement.

7) The complete procedures should execute the two calibration points :

PH7 calibration

PH4 calibration (or PH10 calibration)

- * The calibration procedures should execute start from pH7 calibration then follow pH4 (or pH10) calibration.
- * Rinse the electrode with distilled water again when make each point calibration (pH7, pH4 or pH10).
- * Repeat above two points procedures two times at least.

6. CONDUCTIVITY/TDS MEASURING and CALIBRATION PROCEDURE

The meter default function are following :

- * The display unit is set to conductivity (uS, mS).
- * The temperature unit is set to °C.
- * Temp. compensation factor is set to 2.0% per C.
- * Auto range.
- * Auto power off.
- * The sampling time of data logger function is 2 seconds.

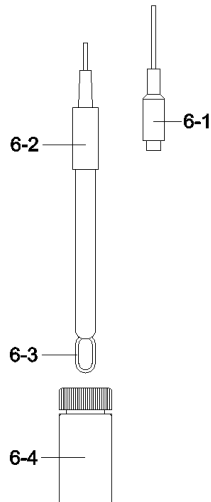

Fig. 3

If the meter along with the conductivity probe are used for a certain period, then it should execute the calibration procedures, refer chapter 6-4, page 21.

6-1 Conductivity measurement

- 1) Prepare the Conductivity Probe (included, CDPB-04), install the " Probe Plug " (6-1, Fig. 3) into the " CD Socket " (3-15, Fig. 1).
- 2) Power on the meter by pressing " Power Button " (3-2, Fig. 1) > 2 Sec., Press and hold the "Function Button" (3-6, Fig. 1) Select the Meter's measurement Mode to " Cd " (Conductivity measurement), refer to chapter 4, page 12.
- 3) Hold the " Probe Handle " (6-2, Fig. 3) by hand and let the " Sensing head " (6-3, Fig. 3) immersed wholly into the measured solution. Shake the probe to let the probe's internal air bubble drift out from the sensing head.
Display will show the conductivity mS (uS) values.
at the same time the left bottom display will show the Temp. value of the measured solution.

Manual range operation

The meter is default to be used for the auto range mode. Push the " Range Button " (3-5, Fig. 1) once in sequence will change the range from 20 uS, 200 uS, 2 mS, 20 mS, 200 mS and auto range.

Change the Temp. unit to °F

If intend to change the Temp. unit from °C to °F, please refer to chapter 12-7 page 43.

Change the Temp. Coefficient Factor

The default Temp. compensation factor value of the measurement solution is to 2.0% per °C. If intend to change it, please refer to chapter 12-11, page 45.

6-2 TDS /Salt/Hardness/Resister measurement

The measuring procedures are same as above

Press the "Function Button" (3-6, Fig. 1) once , to select Conductivity/TDS /Salt/Hardness/Resister mesure in squer.

6-3 Zero Calibration

If the probe not immerse the measurement solution and display not show zero value,

Use the two fingers to press the " ▲ Button " (3-5, Fig. 1), and " ▼ Button " (3-6, Fig. 1) ,Until Display will show the following screen then release the both fingers.

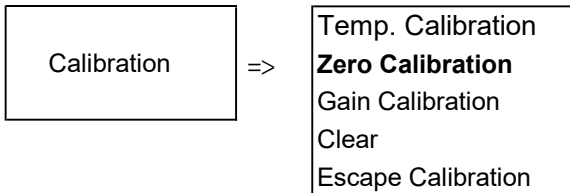

Press the " ▲ Button " (3-5, Fig. 1) or " ▼ Button " (3-6, Fig. 1) select to Zero calibration point, then press enter key the display will show display show zero, The zero function only valid for the 200 uS range and the not zero value is < 2.0 uS.

6-4 Calibration

1) Prepare the standard conductivity solution (optional)

For example :

2 mS range calibration solution :

1.413 mS Conductivity Standard Solution, CD-14

200 uS range calibration solution :

80 uS Conductivity Standard Solution

20 mS range calibration solution :

12.88 mS Conductivity Standard Solution

or other Conductivity Standard Solution

2) Install the " Probe Plug " (6-1, Fig. 3) into the " CD Socket " (3-15, Fig. 1).

- 3) Power on the meter by pressing " Power Button "(3-2, Fig. 1) > 2 Sec., press the "Function (3-6 Fig1)" Select the Meter's measurement screen to the only " Conductivity "screen.
- 4) Hold the " Probe Handle " (6-2, Fig. 3) by hand and let the " Sensing head " (6-3, Fig. 3) immersed wholly into the measured solution. Shake the probe to let the probe's internal air bubble drift out from the sensing head.Display will show the conductivity mS (uS) values.
- 5) Use the two fingers to press the " ▲ Button " (3-5, Fig. 1), and " ▼ Button " (3-6, Fig. 1) ,Until Display will show the following screen then release the both fingers.

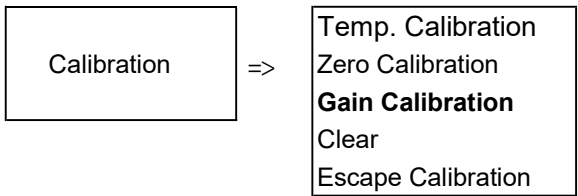

Press the " ▲ Button " (3-5, Fig. 1) or " ▼ Button " (3-6, Fig. 1) select to Gain calibration point.

- 6) Press the " Enter Button " (3-8, Fig. 1), the measuring value will present on both upper and lower Display. Use "▲ Button " (3-5, Fig. 1), " ▼ Button " (3-6, Fig. 1) to adjust the up display value exact same as the standard conductivity value. Press the " Enter Button " (3-8, Fig. 1) will save the calibration data and finish the calibration procedures.

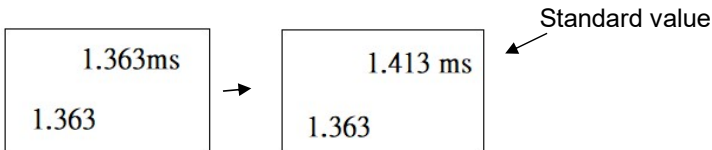

*** If only intend to make the one point calibration, just execute the 2 mS range (1.413 mS Cal.) is enough.**

*** Multi-points calibration procedures should execute the 2 mS range (1.413 mS Cal.) calibration at first, then make other ranges (20 uS range, 20 mS range or 200 mS range) calibration procedures following if necessary.**

- 7) If select the clear point, press the " Enter Button " (3-8, Fig. 1) will clear existing calibration data.
- 8) If select the Escape Calibration, press the " Enter Button " (3-8, Fig. 1) will Escape Calibration Function and back normal measurement.

7. SALT MEASURING and CALIBRATION

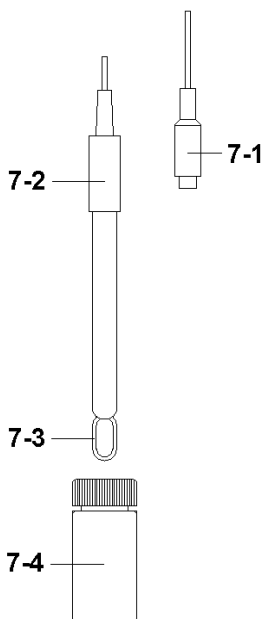

Fig. 4

7-1 Salt measurement

- 1) Prepare the Conductivity Probe (included, CDPB-04), install the " Probe Plug " (7-1, Fig. 4) into the " CD Socket " (3-15, Fig. 1).
- 2) Power on the meter by pressing " Power Button " (3-2, Fig. 1) > 2 Sec.
Select the Meter's measurement Mode to " Salt " (Conductivity measurement)
- 3) Hold the " Probe Handle " (7-2, Fig. 4) by hand and let the " Sensing head " (7-3, Fig. 4) immersed wholly into the measured solution. Shake the probe to let the probe's internal air bubble drift out from the sensing head.
Display will show the Salt values (% weight).

7-2 Calibration

If the conductivity range already make the calibration completely then the Salt measurement is not necessary to make the calibration again.

8. DO (Dissolved Oxygen) MEASURING and CALIBRATION PROCEDURE

8-1 Dissolved Oxygen measurement

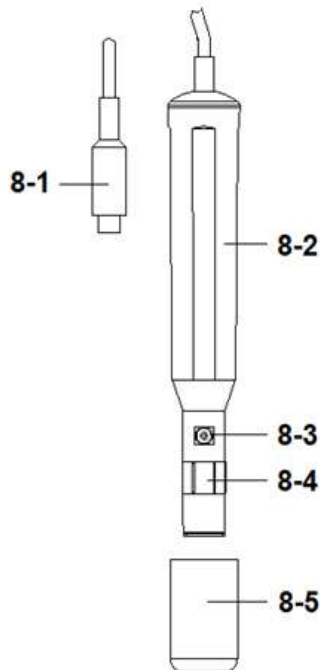

Fig. 5

- 1) Prepare the Oxygen Probe (optional, OXPB-11), install the " Probe Plug " (8-1, Fig. 5) into the " DO Socket " (3-14, Fig. 1).
- 2) Power on the meter by pressing " Power Button " (3-2, Fig. 1) > 2 seconds.
Select the Meter's mode to " do " (Dissolved Oxygen) measurement, refer to chapter 4, page 12.

Calibration at first !

If it is the first time to use the Dissolved Oxygen meter or after a certain period to use the meter again, then it should to execute the calibration procedures at the first. For the measurement precisely consideration, it recommend to make the calibration before each measurement. Calibration procedure, refer to chapter 8-2, page 28.

- 3) a. Immersed the probe to a depth at least 10 cm of the measured liquid in order for the probe to be influenced by the temperature & automatic temperature compensation to take place.
 - b. As for the thermal equilibrium to occur between the probe & the measurement sample must be allowed to pass, which usually amounts to a few minutes if the Temp. difference between the two is only several Celsius degrees.
- 4) a. In order to measure the dissolved oxygen content in any given liquid, it is sufficient to immerse the tip of the probe in the solution, making sure that velocity of the liquid coming into contact with the probe is at least 0.2 - 0.3 m/s or to shake the probe.
 - b. During laboratory measurements, the use of a magnetic agitator to ensure a certain velocity in the fluid is recommended. In this way, errors due to the diffusion of the oxygen present in the air in the solution are reduced to a minimum.

- 5) Display will show the Dissolved Oxygen values (mg/L) at the same time the bottom display will show the Temp. value of the measured solution.
- 6) Rinsed the probe accurately with normal tap water after each series of measurement.

Oxygen in the air

During the DO measurement, press the " Function Button " (3-6, Fig. 1) once, the display unit will show " %O2 " instead of " mg/L " , it show the air Oxygen value for reference.

@ Press the " Function Button " once again, the Display unit will return to " mg/L " .

Change the Temp. unit to °F

If intend to change the Temp. unit from °C to °F, please refer to chapter 12-7, page 43.

"% Salt" compensation value adjustment

If intend to change the % Salt compensation value, refer chapter 12-8, page 44.

"Height" compensation value adjustment

If intend to change the Height compensation value, refer to chapter 12-9, 12-10, page 44 page 45.

8-2 Calibration

- 1) Install the " Probe Plug " (8-1, Fig. 5) into the " DO Socket " (3-14, Fig. 1).
- 2) Power on the meter by pressing " Power Button " (3-2, Fig. 1) > 2 seconds.
 - * Select the Meter's mode to " do " (Dissolved Oxygen) measurement.
 - * Press the " Function Button " (3-6, Fig. 1) Select the Meter's measurement screen to the only " Oxyzen "screen.
- 3) **Wait for approx. 5 minutes at least until the display reading values become stable & no fluctuation.**
- 4) Use the two fingers to press the " ▲ Button " (3-5, Fig 1) and " ▼ Button " (3-6, Fig. 1) at the same time, the display will show the following screen as example, release the both fingers.

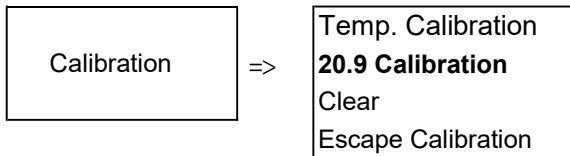

- 5) Press the " Enter Button " , the Display value will count from 30 to 0 screen (a), then return to normal measuring screen (b) and finish the calibration procedures. The complete calibration procedures will take 30 seconds approximately.

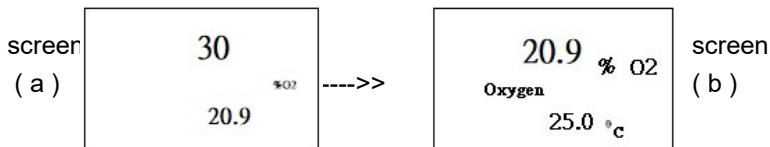

Press the " Function Button " (3-6, Fig. 1) once, to let Display unit to return " mg/L " .

Calibration Consideration :

- a. **As the oxygen in air is 20.9 % typically, so use the environment air O2 value for quick & precise calibration.**
- b. **Please process calibration procedures under wide and ventilating environment for best effect.**

8-3. Probe maintenance

User first time to use the meter

Intend to let the DO probe keep the best condition, when user receive the Oxygen Probe, it should fill the Probe's Electrolyte at first.

User already use the probe for a certain period :

Whenever user can not calibrate the meter properly or the meter's reading value is not stable, please check the oxygen probe to see if the electrolyte in the probe head container is run out or the diaphragm (probe head with diaphragm set) exist problem (dirty). If yes, please fill the electrolyte or change the " Probe head with diaphragm set " and make the new calibration.

The consideration of Diaphragm (probe head with diaphragm set)

The oxygen probe component is the thin Teflon diaphragm housed in the tip of the probe. The diaphragm is permeable by the oxygen molecules but not by the considerably larger molecules contained in the electrolyte. Due to this characteristic, the oxygen may diffuse throughout the electrolyte solution contained in the probe, and its concentration may be quantified by the measurement circuit.

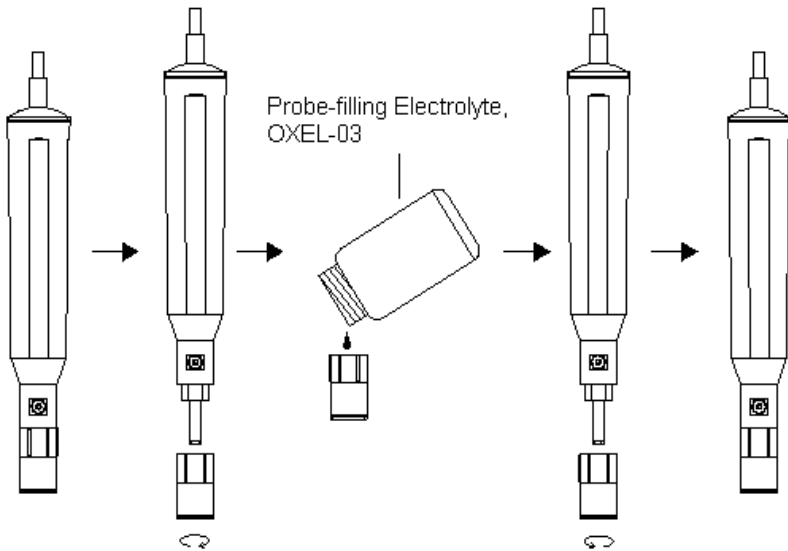

- 1) Unscrew the " Probe head " (9-3, Fig 6).
- 2) Pour out the old Electrolyte from the container of the " Probe head " .
- 3) Fill the new Electrolyte (OXEL-03) into the container of the " Probe head " .
- 4) Screw the " Probe head " (9-3, Fig 6) into the probe body.
- 5) **When not use the probe, should insert the " Probe head " into the " Probe protection cover " (8-5, Fig. 5)**

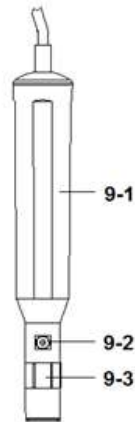

Fig. 6

- 9-1 Probe handle
- 9-2 Temp. sensing metal
- 9-3 Probe head

9. OTHER FUNCTION

9-1 Data Hold

During the measurement, press the " Hold Button " (3-3, Fig. 1) once will hold the measured value & the LCD will display a " HOLD " symbol.

Press the " Hold Button " once again will release the data hold function.

9-2 Data Record (Max., Min. reading)

- 1) The data record function records the maximum and minimum readings. Press the " REC Button " (3-4, Fig. 1) once to start the Data Record function and there will be a " REC " symbol on the display.
- 2) With the " REC " symbol on the display :
 - a) Press the " REC Button " (3-4, Fig. 1) once, the " REC MAX " symbol along with the maximum value will appear on the display.
 - b) Press the " REC Button " (3-4, Fig. 1) again, the " REC MIN " symbol along with the minimum value will appear on the display.
 - c) Press the " REC Button " (3-4, Fig. 1) again, the " MIN " symbol, will be appeared, LCD only show the " REC " symbol. the meter start the Data Record finction again.
 - d) To exit the memory record function, just press the " REC " button for 2 seconds at least. The display will revert to the current reading.

9-3 LCD brightness select

Depending on the brightness of the environment, can use the "Backlight Button " (3-2, Fig. 1) select from 3rd-order LCD Backlight brightness.

10. DATALOGGER

10-1 Preparation before execute datalogger function

a. Insert the SD card

Prepare a " SD memory card " (1 GB to 16 GB, optional),insert the SD card into the " SD card socket " (3-20, Fig. 1).The front panel of the SD card should face against the down case.

b. SD card Format

If SD card just the first time use into the meter, it recommend to make the " SD card Format " at first. ,please refer chapter 12-1, page 40.

c. Time setting

If the meter is used at first time, it should to adjust the clock time exactly, please refer chapter 12-2, page 40.

d. Decimal format setting

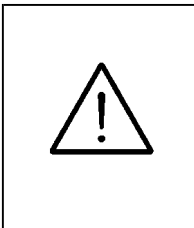

The numerical data structure of SD card is default used the " ." as the decimal, for example "20.6" "1000.53" . But in certain countries (Europe ...) is used the " , " as the decimal point, for example " 20, 6 " "1000,53". Under such situation, it should change the Decimal character at first, details of setting the Decimal point, refer to Chapter 12-6, page 43.

10-2 Auto Datalogger (Set sampling time ≥ 1 second)

a. Start the datalogger

Press the " LOG Button " (3-8, Fig. 1) > 2 Sec. , the LCD will show the text " Scan Card ", then back measure value, and LCD up block will show text " LOGGER " will flashing, at the same time the measuring data along the time information will be saved into the memory circuit.

Remark :

- * *How to set the sampling time, refer to Chapter 12-3 page 41.*
- * *How to set the beeper sound is enable, refer to Chapter 12-5, page 42.*

b. Pause the datalogger

During execute the Datalogger function , if press the " Logger Button " (3-8, Fig. 1) once will pause the Datalogger function (stop to save the measuring data into the memory circuit temporally). In the same time the text of " LOGGER " will be no flashing.

Remark :

If press the " Logger Button " (3-8, Fig. 1) once again will execute the Datalogger again, the bottom text of " LOGGER " will flashing .

c. Finish the Datalogger

During pause the Datalogger, press the " LOG Button " (3-8, Fig. 1) continuously at least two seconds, the " REC " indication will be disappeared and finish the Datalogger.

10-3 Manual Datalogger (Set sampling time = 0 second)

a. Set sampling time is to 0 second

Press the " LOG Button (3-8, Fig. 1) > 2 Sec. , the LCD up block will show the text " LOGGER ", then press the " Logger Button " (3-8, Fig. 1) once, the up block text " LOGGER " will flashing once and Beeper will sound once, at the same time the measuring data along the time information will be saved into the memory circuit. The lower Display will show the Position (Location) no. and saved into the SD card too.

Remark :

During execute the Manual Datalogger, press the " ▲ Button " (3-5, Fig, 1) the lower no. (position no.) will flashing. It can use the " ▲ Button " (3-5, Fig. 1) or " ▼ Button " (3-6, Fig. 1) to set the measuring position (1 to 99, for example room 1 to room 99) to identify the measurement location , the lower Display will show P x (x = 1 to 99).

b. Finish the Datalogger

Press the " LOG Button " (3-8, Fig. 1) continuously at least two seconds, the " LOGGER " indication will be disappeared and finish the Datalogger.

10-4 To check the time and sampling time information

During the normal measurement screen (not execute the Datalogger),

If press " Time Button " (3-7, Fig. 1) once , the LCD display lower block will show present the time and sampling time information of Year/Month/Date/Hour/Minute/Second (h.m.s).
Approx. 5 Sec. the LCD will return to normal screen.

10-5 SD Card Data structure

- 1) When the first time, the SD card is used into the meter, the SD card will generate a route :

WAC01

- 2) If the first time to execute the Datalogger, under the route WAC01\, will generate a new file name WAC01001.XLS.
After exist the Datalogger, then execute again, the data will save to the WAC01001.XLS until Data row reach to 30,000 rows, then will generate a new file, for example WAC01002.XLS
- 3) Under the folder WAC01\, if the total files more than 99 files, will generate a new route, such as WAC02\

4) The file's route structure :

WAC01\
.....

WAC01001.XLS

WAC01002.XLS

.....
WAC01099.XLS

WAC02\
.....

WAC02001.XLS

WAC02002.XLS

.....
WAC02099.XLS

WACXX\
.....
.....

Remark :

XX : Max. value is 10.

11. Saving data from the SD card to the computer (EXCEL software)

- 1) After execute the Data Logger function, take away the SD card out from the " SD card socket " (3-20, Fig. 1).
- 2) Plug in the SD card into the Computer's SD card slot (if your computer build in this installation) or insert the SD card into the " SD card adapter ". then connect the " SD card adapter " into the computer.
- 3) Power ON the computer and run the " EXCEL software ". Down load the saving data file (for example the file name : WAC01001.XLS, WAC01002.XLS) from the SD card to the computer. The saving data will present into the EXCEL software screen (for example as following EXCEL data screens) , then user can use those EXCEL data to make the further Data or Graphic analysis usefully.

EXCEL data screen (for example 1)

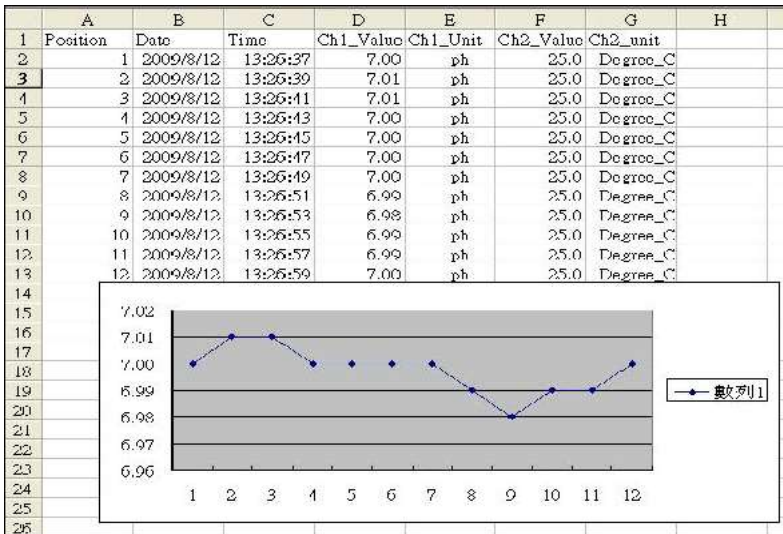

EXCEL data screen (for example 2)

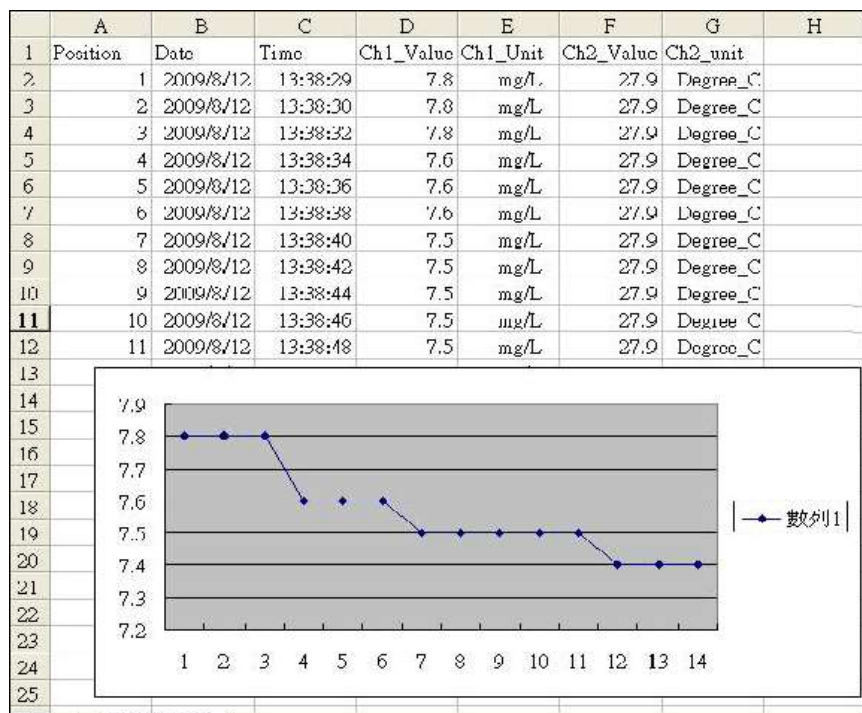

EX

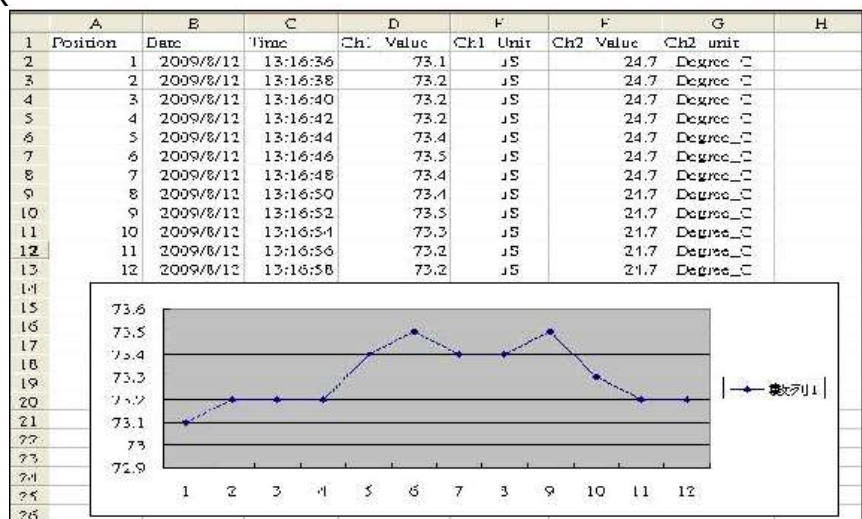

12. ADVANCED SETTING

Under do not execute the Datalogger function, press the " SET Button " (3-8, Fig. 1) continuously at least two seconds will enter the " Advanced Setting " mode. then press the " SET Button " (3-8, Fig. 1) once a while in sequence to select the eight main function, the display will show :

SD FORMAT	SD memory card Format
CLOCK TIME	Set clock time (Year/Month/Date, Hour/Minute/Second)
SAMPLE TIME	Set sampling time (Second)
AUTO POWER OFF	Auto power OFF management
BEEPER SOUND	Set beeper sound ON/OFF
DECIMAL POINT	Set SD card Decimal character
TEMPRATURE UNIT	Select the Temp. unit to °C or °F
DO SALT % COMP.	Set DO salt% compensation, DO only
DO Hight (meter) COMP.	Set DO height (meter) compensation, DO only
DO Hight (feet)COMP.	Set DO height (feet) compensation, DO only
CD Temprature COMP.	Set CD temperature compensation factor.
PH Manual Temp, COMP.	Set pH manual Temp. compensation value.
ESCAPE SETTING	Escape from the advanced setting

Remark :

- a. *DO - Dissolved oxygen Mode*
CD - Conductivity/TDS Mode
pH - pH/mV Mode
- b. *During execute the " Advanced Setting " function, if press " ESC Button " (3-3, Fig. 1) will exit the " Advanced Setting " function, the LCD will return to normal screen.*

12-1 SD memory card Format

When the " SD FORMAT " text is yellow color

- 1) Press "Enter" into the setting function, then use the " ▲ Button " (3-5, Fig. 1) or " ▼ Button " (3-6, Fig. 1) to select the upper value to " Yes " or " No ".

Yes - Intend to format the SD memory card

No - Not execute the SD memory card format

- 2) If select the upper to " Yes ", press the " Enter Button " (3-4, Fig. 1) once again, the Display will show text " Enter " to confirm again, if make sure to do the SD memory card format, then press " Enter Button " once will format the SD memory clear all the existing data that already saving into the SD card.

12-2 Set clock time (Year/Month/Date, Hour/Minute/ Second)

When the " CLOCK TIME " text is yellow color

- 1) Press "Enter" into the setting function, then use the " ▲ Button " (3-5, Fig. 1) or " ▼ Button " (3-6, Fig. 1) to adjust the value (Setting start from Year value). After the desired value is set, press the " Enter Button " (3-4, Fig. 1) once will going to next value adjustment (for example, first setting value is Year then next to adjust Month, Date, Hour, Minute, Second value).

Remark :

The adjusted value will be flashed.

2) After set all the time value (Year, Month, Date, Hour, Minute, Second), press the " Enter Button " (3-8, Fig. 1) once will save the time value, then the screen will jump to " Sampling time " setting screen (Chapter 12-3).

Remark :

After the time value is setting, the internal clock will run precisely even Power off if the battery is under normal condition (No low battery power).

12-3 Set sampling time (Second)

When the " SAMPLE TIME " text is yellow color

1) Press "Enter" into the setting function, then use the " ▲ Button " (3-5, Fig. 1) or " ▼ Button " (3-6, Fig. 1) to adjust the value (Setting start from value)1,2,5,10,30,60,120,180,300, 600,1800,3600 Sec., After the desired value is set, press the " Enter Button " (3-4, Fig. 1) once will save the sampling value with default then the screen will jump to " Auto power OFF " setting screen (Chapter 12-4).

Remark :

The adjusted value will be flashed.

12-4 Auto power OFF management

When the " AUTO POWER OFF " text is yellow color

- 1) Press "Enter" into the setting function, then use the " ▲ Button " (3-5, Fig. 1) or " ▼ Button " (3-6, Fig. 1) to select the upper value to " Yes " or " No ".

Yes - Auto Power Off management will enable.

No - Auto Power Off management will disable.

- 2) After select the upper text to " Yes " or " No ", press the " Enter Button " (3-8, Fig. 1) will save the setting function with default.

12-5 Set beeper sound ON/OFF

When the " BEEPER SOUND " text is yellow color

- 1) Press "Enter" into the setting function, then use the " ▲ Button " (3-5, Fig. 1) or " ▼ Button " (3-6, Fig. 1) to select the upper value to " Yes " or " No ".

Yes- Meter's beep sound will be ON with default.

**No - Meter's beep sound will be OFF with default.
is power ON.**

- 2) After select the upper text to " Yes " or " No ", press the " Enter Button " (3-8, Fig. 1) will save the setting function with default.

12-6 Decimal point of SD card setting

The numerical data structure of SD card is default used the "." as the decimal, for example "20.6" "1000.53". But in certain countries (Europe ...) is used the "," as the decimal point, for example " 20,6 " "1000,53". Under such situation, it should change the Decimal character at first.

When the " DECIMAL POINT " text is yellow color

- 1) Press "Enter" into the setting function, then use the " ▲ Button " (3-5, Fig. 1) or " ▼ Button " (3-6, Fig. 1) to select the upper text to " USA " or " EURO ".

USA - Use "." as the Decimal point with default.

EURO- Use ",", " as the Decimal point with default.

- 2) After select the upper text to " USA " or " EURO ", press the " Enter Button " (3-8, Fig. 1) will save the setting function with default.

12-7 Select the Temp. unit to °C or °F

When the " TEMPRATURE UNIT " text is yellow color

- 1) Press "Enter" into the setting function, Then use the " ▲ Button " (3-5, Fig. 1) or " ▼ Button " (3-6, Fig. 1) to select the upper Display text to " C " or " F ".

C - Temperature unit is °C

F - Temperature unit is °F

- 2) After Display unit is selected to " C " or " F ", press the " Enter Button " (3-8, Fig. 1) will save the setting function with default.

12-8 Set DO salt% compensation value

When the " DO SALT % COMP. " text is yellow color

- 1) This function only for the DO (Disolved oxygen) mode of adjusting the probe's salt% compensation value. The default value is 0% salt.
- 2) Press "Enter" into the setting function,Then use the " ▲ Button " (3-5, Fig. 1) or " ▼ Button " (3-6, Fig. 1) to select the upper value to the desired salt% compensation value, then press the " Enter" Enter Button " (3-8, Fig. 1) will save the setting value temporally.

12-9 Set DO height (meter) compensation value

When the " DO Hight (meter) COMP. " text is yellow color

- 1) This function only for the DO (Disolved oxygen) mode of adjusting the probe's height compensation value in meter unit. The default value is 0 meter.
- 2) Press "Enter" into the setting function,then use the " ▲ Button " (3-5, Fig. 1) or " ▼ Button " (3-6, Fig. 1) to select the upper value to the desired height compensation value (meter), then press the " Enter Button " (3-8, Fig. 1) will save the setting value temporally.

12-10 Set DO height (feet) compensation value

When the " DO Hight (feet)COMP. " text is yellow color

- 1) This function only for the DO (Disolved oxygen) mode of adjusting the probe's height compensation value in feet unit. The default value is 0 FEET.
- 2) Press "Enter" into the setting function,then use the " ▲ Button " (3-5, Fig. 1) or " ▼ Button " (3-6, Fig. 1) to select the upper value to the desired height compensation value (feet), then press the " Enter Button " (3-8, Fig. 1) will save the setting value temporally.

12-11 Set CD temperature compensation factor

When the " CD Temperature COMP. " text is yellow color

- 1) This function only for the Conductivity (TDS) mode of adjusting the probe's Temp.compensation value in % per °C unit. The default value is 2 % per °C.
- 2) Press "Enter" into the setting function,then use the " ▲ Button " (3-5, Fig. 1) or " ▼ Button " (3-6, Fig. 1) to select the upper value to the desired Temp. compensation value (%/per °C), then press the " Enter Button " (3-8, Fig. 1) will save the setting value temporally.

12-12 Set pH manual Temp. compensation value

When the " PH Manual Temp, COMP. " text is yellow color

- 1) This function only for the pH measurement of adjusting the pH electrode's manual Temp.compensation value. The default value is 25 °C (77 °F).
- 2) Press "Enter" into the setting function,then use the " ▲ Button " (3-5, Fig. 1) or " ▼ Button " (3-6, Fig. 1) to select the upper value to the desired Temp. compensation value (°C or °F), then press the " Enter Button " (3-8, Fig. 1) will save the setting value with default.

12-13 ESCAPE SETTING

When the " ESCAPE SETTING " text is yellow color

When the Display show the text " ESC ", then press the " ESC Button " (3-3, Fig. 1) will finish the Advanced Setting procedures and return to the normal measuring screen.

Remark :

During execute the " Advanced Setting " function,if press " ESC Button " (3-3, Fig. 1) will exit the " Advanced Setting " function, the LCD will return to normal screen.

13. POWER SUPPLY from DC ADAPTER

The meter also can supply the power supply from the DC 9V Power Adapter (optional). Insert the plug of Power Adapter into DC 9V Power Adapter Input Socket " (3-17, Fig. 1). Press the " power button " > seconds ,The meter will power ON

14. BATTERY REPLACEMENT

- 1) When the left corner of LCD display show "  ", it is necessary to replace the battery. However, in-spec. measurement may still be made for several hours after low battery indicator appears before the instrument become inaccurate.
- 2) Loose the screws of the " Battery Cover " (3-11, Fig. 1) and take away the " Battery Cover " from the instrument and remove the battery.
- 3) Replace with DC 1.5 V battery (UM3, AA, Alkaline/heavy duty) x 6 PCs, and reinstate the cover.
- 4) Make sure the battery cover is secured after changing batteries.

15. SYSTEM RESET

If the meter happen the troubles such as :

CPU system is hold (for example, the key button can not be operated...).

Then make the system RESET will fix the problem. The system RESET procedures will be either following method :

During the power on, use a pin to press the " Reset Button " (3-18, Fig. 1) once a while will reset the circuit system.

16. RS232 PC SERIAL INTERFACE

The instrument has RS232 PC serial interface via a 3.5 mm terminal (3-19, Fig. 1).

The data output is a 16 digit stream which can be utilized for user's specific application.

A RS232 lead with the following connection will be required to link the instrument with the PC serial port.

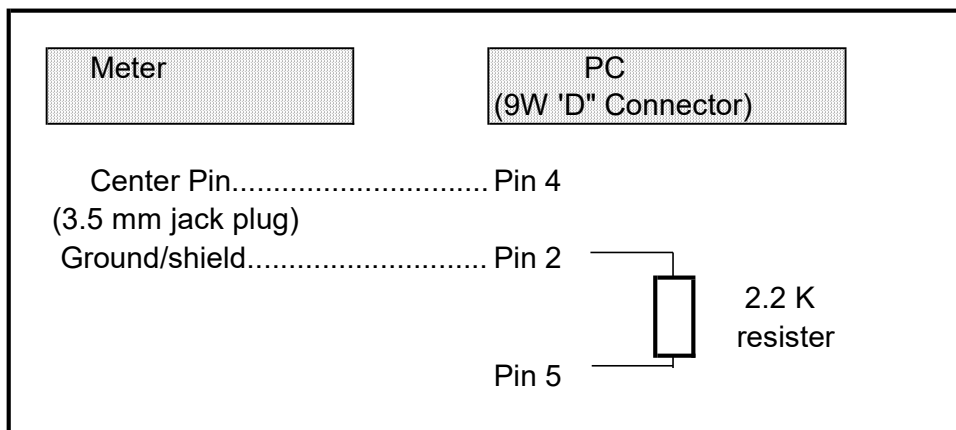

The 16 digits data stream will be displayed in the following format :

D15 D14 D13 D12 D11 D10 D9 D8 D7 D6 D5 D4 D3 D2 D1 D0

Each digit indicates the following status :

D15	Start Word
D14	4
D13	ATC, Temp.= 1, Ph=2, mV=3, DO Temp.= 4, O ² =5 CD Temp.= 6, CD=7, TDS =8, Salt%=A, Hardness=B, Resistanc=C

D12, D11	Annunciator for Display		
	uS = 13	mS = 14	PPM = 19
	PH = 05	mV = 18	% = 03
	mg/L = 07	% O2 = 06	ohm =38
	Kohm = 39	Mohm = 40	Temp. = 01
D10	Polarity 0 = Positive 1 = Negative		
D9	Decimal Point(DP), position from right to the left 0 = No DP, 1= 1 DP, 2 = 2 DP, 3 = 3 DP		
D8 to D1	Display reading, D1 = LSD, D8 = MSD For example : If the display reading is 1234, then D8 to D1 is : 00001234		
D0	End Word		

RS232 FORMAT : 9600, N, 8, 1

Baud rate	9600
Parity	No parity
Data bit no.	8 Data bits
Stop bit	1 Stop bit

17. OPTIONAL ACCESSORIES

RS232 cable UPCB-02	* Computer interface cable. * Used to connect the meter to the computer (COM port).
USB cable USB-01	* Computer interface cable. * Used to connect the meter to the computer (USB port).

Data Acquisition software SW-U801-WIN	* The SW-U801-WIN is a multi displays (1/2/4/6/8 displays) powerful application software, provides the functions of data logging system, text display, angular display, chart display, data recorder high/low limit, data query, text report, chart report.. .xxx.mdb data file can be retrieved for EXCEL, ACCESS.., wide intelligent applications.
--	---

Power adapter	AC 110V to DC 9V. USA plug.
Power adapter	AC 220V/230V to DC 9V. Germany plug.

PH optional accessories	* PH Electrode, 1 to 13 pH. Model : PE-11
	* PH Electrode, 1 to 13 pH. Model : PE-03
	* PH Electrode, 0 to 14 pH. Model : PE-01
	* Temperature probe (ATC probe) Model : TP-07
	* SPEAR PH Electrode Model : PH-06HDA, PH-04HD
	* PH Electrode + Temp. probe, 2 in 1 Model : PE-03K7
	* PH 7 BUFFER SOLUTION Model : PH-07
* PH 4 BUFFER SOLUTION Model : PH-04	

Conductivity Salt optional accessories	* Conductivity/Salt probe Model : CDPB-03
	* 1.413 mS standard solution. Model : CD-14

Dissolved Oxygen optional accessories	* Oxygen probe Model : OXPB-11
	* Spare Probe head with Diaphragm set Model : OXHD-04
	* Probe-filling Electrolyte Model : OXEL-03

ORP	* ORP electrode Model : ORP-14, ORP-15
-----	---

18. PATENT

The meter (SD card structure) already get patent or patent pending in following countries :

Germany	Nr. 20 2008 016 337.4
JAPAN	3151214
CHINA	ZL 2008 2 0189918.5
	ZL 2008 2 0189917.0